



**JOINT INSTITUTE FOR NUCLEAR RESEARCH**

FINAL REPORT ON

**Detector Control Systems at ALICE of  
CERN with comparison of BM@N of NICA**

**Supervisor:** Mr Nikita Baldin

**Prepared by:** Alaa Elsadieque

Senior Clinical Research Coordinator, Alexandria University Cancer research cluster

Ph.D student Medical Biophysics, Medical Research institute, Alexandria University

Participation period: Wave 9 (30 Oct - 10 Dec)

**Egypt, 2023**

## **The assigned task description:**

A comparison of Detector Control Systems at the BM@N experiment in JINR and the ALICE experiment at CERN

- Find standards around topic
- Find any examples of this type of comparison
- Describe decomposition to
- Create list of comparable parameters

## **Contents:**

<b>Introduction</b>	<b>3</b>
<b>ALICE sub-detectors</b>	<b>6</b>
<b>ALICE Muon Tracking Chambers (MCH)</b>	<b>6</b>
<b>FORWARD DIFFRACTIVE DETECTOR</b>	<b>7</b>
<b>Time Projection Chamber Particle Detector:</b>	<b>10</b>
<b>Inner Tracking System (ITS)</b>	<b>11</b>
<b>Transition Radiation Detector (TRD)</b>	<b>11</b>
<b>Time-Of-Flight (TOF) Detector</b>	<b>13</b>
<b>High Momentum Particle Identification Detector (HMPID)</b>	<b>14</b>
<b>Zero Degree Calorimeter (ZDC)</b>	<b>16</b>
<b>Fast Interaction Trigger (FIT)</b>	<b>17</b>
<b>Charged Particle Veto Detector</b>	<b>17</b>
<b>The ALICE High Level Trigger at the LHC</b>	<b>18</b>
<b>ALICE Control Coordination (ACC)</b>	<b>19</b>
<b>The DCS context and scale</b>	<b>20</b>
<b>Results</b>	<b>21</b>
<b>Future work</b>	<b>29</b>
<b>Acknowledgement</b>	<b>29</b>

## Introduction:

NICA is a new accelerator complex in Russia for studying dense baryonic matter. BM@N is the first experiment, focusing on strange matter in heavy-ion collisions. MPD is a detector for heavy-ion collision experiments, providing particle registration, identification, and vertex reconstruction. Tango Controls is used for monitoring and control of hardware in BM@N and MPD.

The ALICE experiment comprises over 10 detectors with diverse technologies and operational requirements. The Detector Control System (DCS) is designed to integrate these systems hierarchically with defined interfaces between layers. Each sub-detector maintains independent access for maintenance and upgrades, promoting a partitioned, self-contained sub-system architecture. Commercial hardware and software components will be utilized when possible. This structure allows a unified user interface for accessing DAQ control and DCS.

Detectors for LHC experiments are located in inaccessible underground caverns, necessitating remote access due to complex and precise equipment in a harsh environment. Over 10 sub-detectors in ALICE must operate coherently and share data with DAQ and Trigger systems. The ALICE experiment is dynamic, evolving with frequent modifications, and operated in various modes and configurations. Multiple groups develop sub-detectors, requiring integration into a unified control system. These demands justify the need for a state-of-the-art control system.

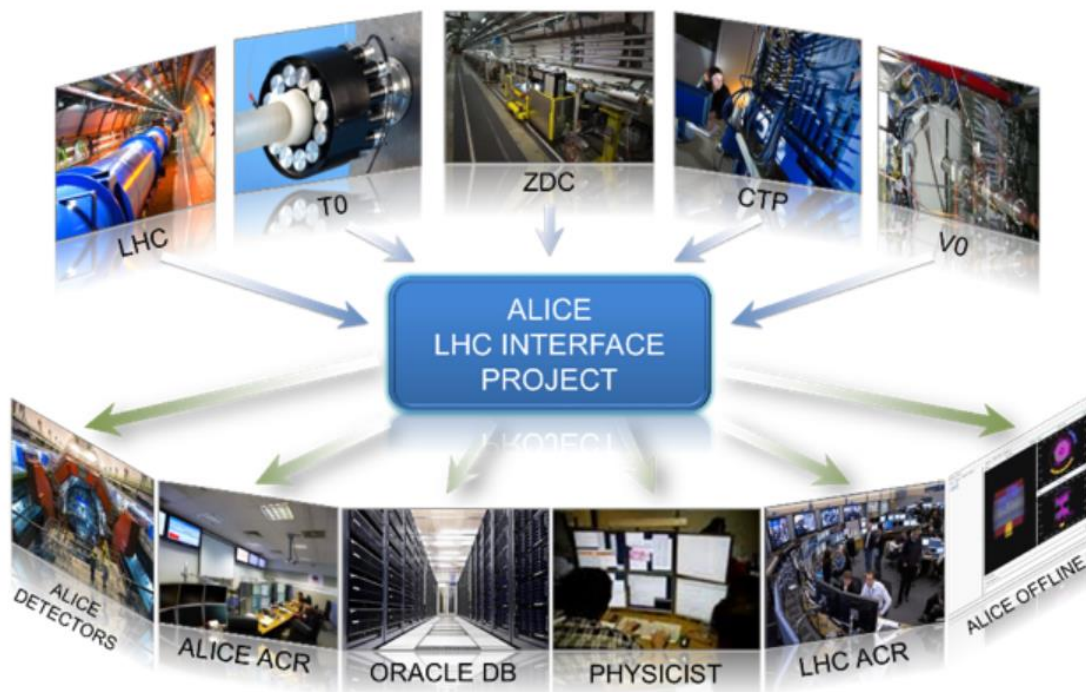

The DCS operates in two major modes:

- Normal operation for physics data collection, ensuring controlled start, operation, and shutdown of sub-detectors. Standard operator commands are available, and alarms notify malfunctions. Data is accessible to other systems like DAQ and archived.
- During maintenance or upgrades, detectors can run separately to avoid interference with other equipment or external services.

<b>SCADA (Supervision &amp; Control)</b>	Workstations (PCs) Server Stations External Systems
<b>Controllers &amp; Network (Device Control &amp; Data Acquisition)</b>	PCs, VME, PLCs Power supplies Gas Control Instruments Magnet Control
<b>Detector (Process parameters)</b>	Custom HW (FEE) Sensors (T, B, F, P, ) Actuators (Vvs,Sws)

ALICE DCS has been designed to:

- Assure a high running efficiency by reducing downtime to a minimum.
- Maximizes the number of readout channels operational at any time.
- measures and stores all parameters necessary for efficient analysis of the physics data.

## Alice Sub-detectors:

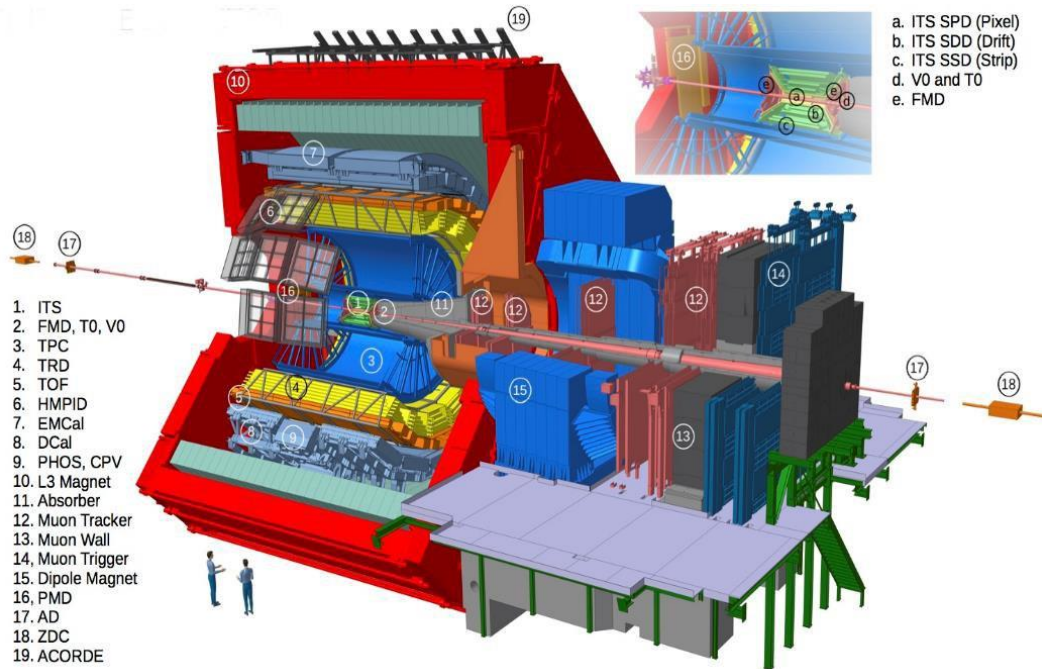

### **1. ALICE Muon Tracking Chambers (MCH):**

It consists of ten planes of tracking chambers designed in five stations. The geometries of the five stations are such that stations one and two are based on a quadrant structure with the electronics distributed densely across its surface. Stations three, four and five have a slat architecture with the electronics mounted on the sides of the chamber. The tracking chambers or CPC are wire chambers operated with a gas mixture of 80% Argon and 20% Carbon Dioxide.

The current DCS infrastructure in ALICE MCH follows a 3-tier architecture. The field management layer, comprising approximately 60 network attached devices, connects to low-voltage and detector FEE devices. The process management layer facilitates communication between MCH devices and control system software using OPC and DIM standard tools. MCH operation aligns with central ALICE procedures, enforced by the SMI++ package representing devices as an FSM in the global ALICE tree.

The User Interface (UI) allows visualization and control of DCS sub-components. In Run 3 (2022), efforts focus on reusing the existing structure while accommodating novel FEE and upgraded low-voltage power supplies.

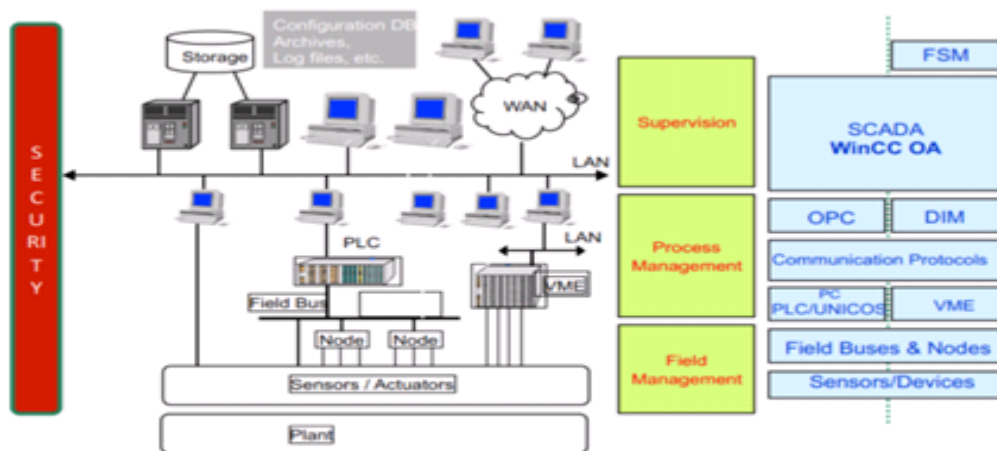

Current general scheme of the MCH DCS

## 2. FORWARD DIFFRACTIVE DETECTOR:

The FIT detector serves as an interaction trigger online illuminometer, initial indicator of the vertex position, and the forward multiplicity counter. The FDD detector is part of one of the three sub-detectors that make up ALICE's FIT project, together with FT0 and FV0 detectors. FDD will contribute with the measurements of the time and luminosity of collisions. It will be used mainly for the study of diffractive physics.

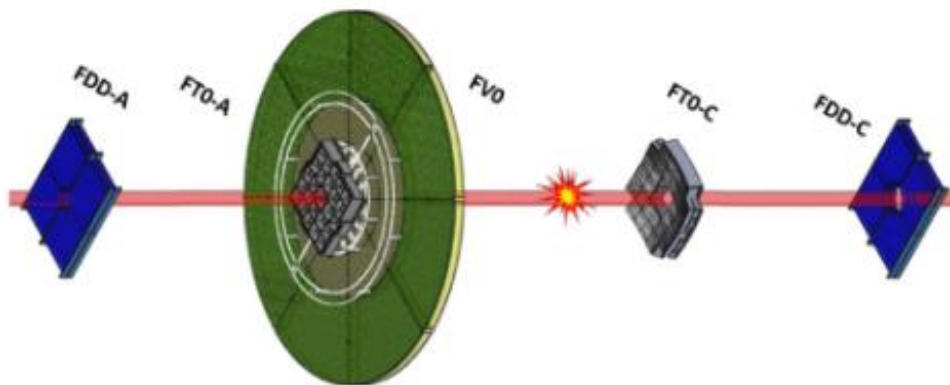



- **Software architecture:**

The DCS will monitor the status of the FDD-A and FDD-C sub-detectors. It will also supervise the electronics present in such experiment, for instance: PM, TCM, and the infrastructure of the experiment, such as the power supply devices and the temperature of the crates where various electronic devices are located.

- **Hardware of the FDD-DCS:**

The hierarchy of the CAEN A7030DP high voltage boards used to power the PMTs was configured in the FDD-DCS using the SCADA system. Such CAEN boards are inserted in the CAEN crate SY4527 located in Counting Room 4 (CR4)

- **Logical of the FDD-DCS:**

Another part of the development of the control system that was done is to configure the logical hierarchy corresponding to the PMTs of the FDD detector on side A and side C of the cavern of the ALICE experiment. This is necessary for the control system to identify the 16 PMTs and read the data from such PMTs during collisions.

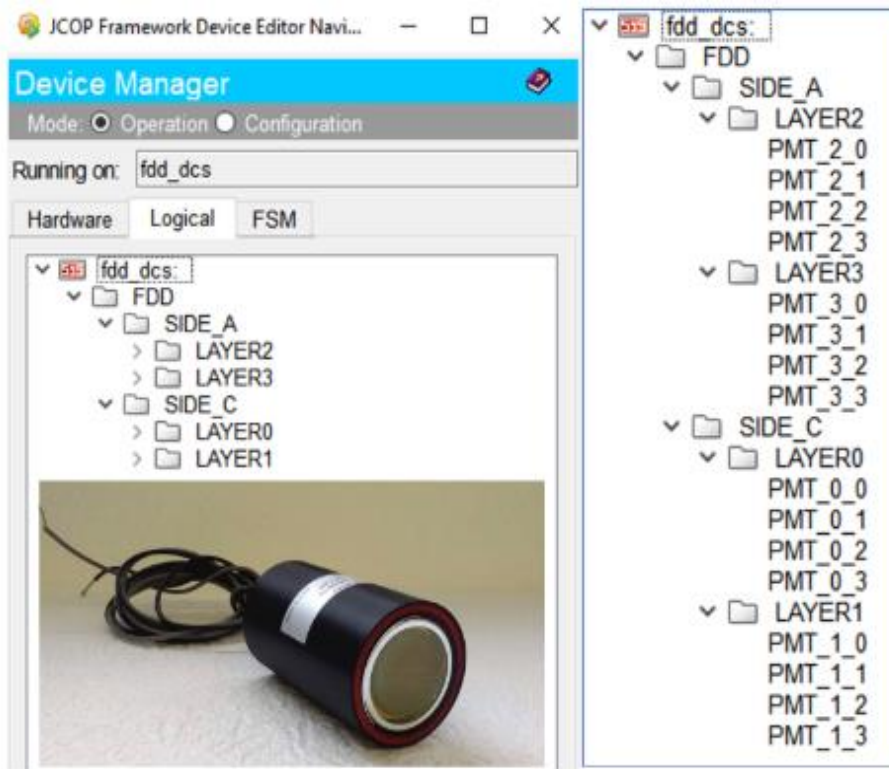

- **User interface and alarms:**

- FDD-DCS main panel
- FDD-A and FDD-C sub-panels
- CAEN boards temperature



## T0 Detector Control System Overview:

### 1. Detector Characteristics:

- **Nature:** T0 detector modules are straightforward, stable, and reliable.
- **Components:** Utilizes standard off-the-shelf products for High Voltage and current monitoring.
- **Challenges:** Stray magnetic fields near L3 magnet and elevated radiation levels are addressed with standard solutions like the EASY system.

### 2. Control System Components:

- **Sub-Systems:** High voltage (HV), low voltage (LV), settings (thresholds, delays), laser control, generator control, T0-TDCs, and T0-DRM readout cards.
- **Electronics Placement:** Shoebox inside the magnet (accessible during long shutdowns), fast electronics, T0 TDC/TDM cards in crates outside L3 (accessible even during short shutdowns).
- **Voltage Supply:** CAEN SY2527 system with high and low voltage boards.
- **Communication:** CAEN OPC server interfaces with PVSS through Ethernet.
- **Optical Link Bridge:** CAEN V2718-A2818 VME-PCI for connections between control computer and VME crates with fast electronics.
- **Development:** T0-TRM and T0-DRM developed by ALICE TOF group.

### 3. Monitoring and Control Signals (See following table):

- **Parameters:** High and low voltage, thresholds, delays, laser pulses, trigger signals, T0-TDCs, and T0-DRM readout cards.
- **Adjustments:** Thresholds, delays, and other parameters may need adjustment before and during the run.

### 4. Communication and Software:

- **CANbus:** Used for control and monitoring of fast electronics.
- **Interface Card:** Kvaser CAN interface card.
- **SCADA System:** Top-level application based on PVSS software.
- **Communication Protocols:** OPC or DIM servers facilitate communication between the SCADA system and hardware.
- **Framework:** Support for all equipment implemented based on the JCOP framework.

### 5. Measurable Parameters:

- **Response Time:** Evaluate the time taken for adjustments and system response.
- **Reliability:** Assess the stability and reliability of the control system components.
- **Communication Efficiency:** Measure the effectiveness of communication protocols.
- **Accessibility:** Evaluate the ease of access during short and long shutdowns.
- **Integration:** Assess the integration of T0-TRM and T0-DRM into the overall control system.

Main parameters of the Detector Control System for the T0.

Subsystem	location	Controlled parameters	Number	Parameter	Control
Fast electr.	VME	delays	24	-	-
		Thresholds for CFD	24	voltage	W
		Thresholds for T0-v	2	voltage	R/W
		Thresholds for multiplicity trigger	-	-	-
T0-TRM	VME crate	same as TOF			
T0-DRM	VME crate	same as TOF			
Low voltage for Shoebox	CAEN 2725	LV supply on/off	24	voltage	R/W
		LV settings and readings	24	complex	R/W
		safety switch	1	voltage	on/off
HV voltage	-	HV supply on/off	24	voltage	R/W
		HV settings and readings	24	complex	R/W
		safety switch	1	voltage	on/off
Laser system	-	switch	1	-	on/off
		attenuator	1	complex	R/W
Generator	-	switch	1	voltage	on/off

### 3. ALICE – Time Projection Chamber Particle Detector:

The TPC detector control system (DCS) is a crucial component of the ALICE experiment, overseeing the control and monitoring of various hardware elements. The DCS comprises three functional layers: field layer (hardware), control layer (information processing), and supervisory layer (user interfaces and central infrastructure).

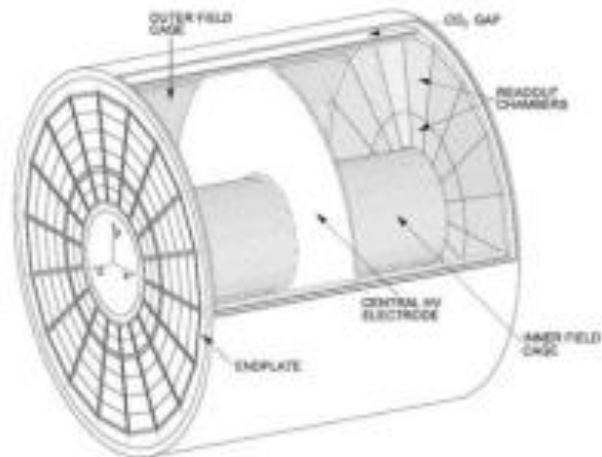

## Measurable Parameters and System Overview:

### 1. Hardware Architecture:

- Field Layer: Power supplies, front-end electronics, etc.
- Control Layer: Devices for collecting and processing information.
- Supervisory Layer: Computers, servers, user interfaces.

### 2. Software Architecture:

- Tree structure representing TPC, subsystems, and devices.
- Control units implemented as finite state machines.

### 3. System Implementation:

- Core software: SIMATIC WinCC Open Architecture (SCADA system).
- Distributed architecture over 12 computers.

### 4. Interfaces to Devices:

- Commercial servers using OPC standard for communication.
- DIM framework for non-commercial hardware.

### 5. Interlocks (Safety Measures):

- Internal, external, and software interlocks.
- Alert system to inform the shift crew of unusual or potentially dangerous situations.

## 4. Inner Tracking System (ITS):

New ITS Configuration:

- Consists of 7 concentric cylindrical layers of Monolithic Active Pixel Sensors (MAPS).
- Utilizes CMOS imaging technology (similar to digital camera sensors).
- Each ALPIDE chip covers an area of 15x30 mm<sup>2</sup> with a granularity of 30 x 30  $\mu\text{m}$ .

Spatial Resolution and Active Area:

- Achieves a spatial resolution of 5  $\mu\text{m}$ , exceeding ALICE ITS requirements.
- Active area spans approximately 10 m<sup>2</sup>, segmented into 12.5 billion pixels.<sup>11</sup>

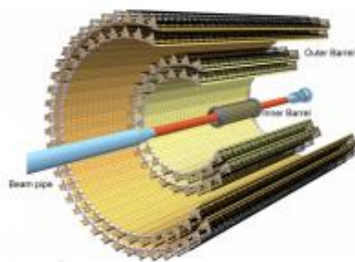

BARREL	LAYERS	RADIUS (cm)	LENGHT (cm)	NUM. STAVES	NUM. CHIPS
Inner	Layer 0	22.4	271	12	108
Inner	Layer 1	30.1	271	16	144
Inner	Layer 2	37.8	271	20	180
Outer	Layer 3	194.4	843	24	2688
Outer	Layer 4	243.9	843	30	3360
Outer	Layer 5	342.3	1475	42	8232
Outer	Layer 6	391.8	1475	48	9408

## 5. Transition Radiation Detector (TRD):

- Accommodate higher data-taking rates without relying on triggers.
- Improve readout time with existing Front-End Electronics (FEE).

Hardware Upgrade:

- Utilization of ALICE Common Read-Out Unit (CRU) for increased bandwidth to the DAQ system.

Operational Advantages:

- Enables optimized FEE data format readout at the full minimum bias event rate.

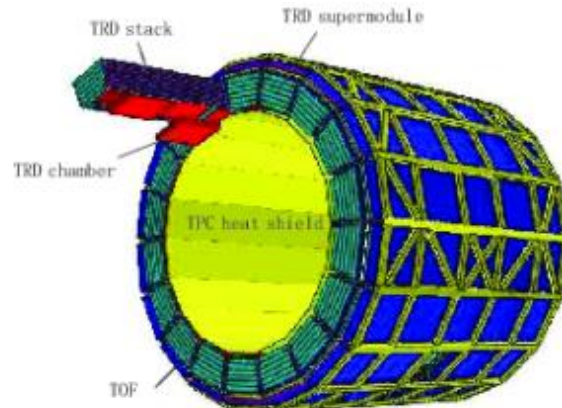

## DCS (Detector Control System) Overview:

### 1. Access and Control:

- Accessed through the Supervisory Control layer.
- No peer-to-peer connection with DAQ.
- Features include global experiment view, command control, sequence generation, communication management, monitoring, alarms, and interlock logic.

### 2. Hardware Structure:

- Three layers: Field (sensors, actuators), Control (PLC and intelligent instruments), Supervisory (workstations).
- Standardized hardware structure across detectors.
- Field instrumentation interfaces follow electrical standards (e.g., 0–10 V, 4–20 mA).

### 3. Communication:

- Ethernet considered for detector control field bus.
- Fast duplex synchronous serial link for communication between DCS controller and MCM (Multi Chip Module).
- Point-to-point links for voltage/current signals; recommended field buses for certain devices.

### 4. Hardware Protection:

- Hardware protection implemented where possible (e.g., ramp-down of sense wire high voltages during sustained over-currents).

### 5. Software:

- Three-phase software development for controllers: MC68EZ328 DragonBall, ALTERA 20K200 FPGA, Altera Excalibur chip.
- Supervisory layer equipped with general-purpose workstations linked to the control layer via TCP/IP.
- MMI (Man-Machine Interface) for configuration, partitioning, alarms, logging, and data communication.
- Linux-based software for controllers, supporting NFS mount, http, secure shell, and telnet.

- Driver software for interfacing follows OPC standard for easy connectivity between hardware and applications.

### Measurable Parameters:

- **Communication Speed:** Utilizing 100 Mbit/s throughput over Ethernet.
- **Hardware Status Monitoring:** Monitoring signals including chip temperature, power voltages/currents, gas temperature, LV connector and cable temperature, LV regulator current and voltage, and humidity.
- **Fault Tolerance:** Ethernet's ruggedness and AC coupling; failure on one branch node doesn't disturb the network.
- **Software Compatibility:** Linux kernels, supporting NFS mount, http, secure shell, and telnet.
- **Integration Standard:** Based on the OPC standard for easy integration with different manufacturers' hardware and applications.

## 6. Time-Of-Flight (TOF) Detector:

HPTDC Readout Rate:

- Upgrade focuses on increasing HPTDC readout rate.
- TRMs and HPTDCs located inside TOF supermodules.

Data Transfer Improvement:

- Data transferred from DRM modules to DAQ via the DDL link.
- Reengineered modules with a more performant FPGA chip and a new version of the DDL link.

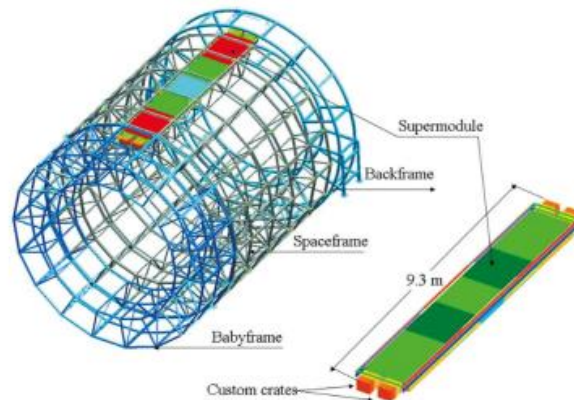

A schematic layout of one of the 18 TOF supermodules inside the ALICE spaceframe

### TOF Detector Monte Carlo Simulations:

#### 1. Detector Layout Options:

- **Detailed Description:** Chapter 3 provides a comprehensive overview of the TOF detector design.

- **Monte Carlo Simulations:** Explored different layout options approximating the final design.

## 2. Software Tools:

- **AliRoot 3.02:** Latest ALICE off-line code in the ROOT framework.
- **GEANT 3.21:** Well-known detector description and tracking package.
- **Programming Language:** C++.
- **Operating Systems:** HP-Unix 10.20, Linux Red Hat 6.0.
- **Event Generators:** JETSET, PYTHIA, HIJING, SHAKER, etc.

## 3. Measurable Parameters:

- **Simulation Environment:** AliRoot with GEANT 3.21.
- **Event Simulation:** Comprehensive set of instruments for ion-ion collision simulation.
- **Software Version:** AliRoot 3.02.
- **Operating Systems:** HP-Unix 10.20, Linux Red Hat 6.0.

## 4. Conclusion:

- **Simulation Tools:** AliRoot 3.02 with GEANT 3.21 for accurate event simulation.
- **Versatility:** Interfaced with various event generators for a complete set of simulation tools.
- **Platform Compatibility:** Installed on HP-Unix and Linux systems.

In summary, the Monte Carlo simulations leverage advanced tools like AliRoot 3.02 and GEANT 3.21, offering a versatile environment for comprehensive event simulations in the context of the TOF detector design.

## 7. High Momentum Particle Identification Detector (HMPID):

Electronics:

Integration into the new ALICE read-out architecture for backward compatibility.

Parallelization:

- a. Potential to increase rate significantly by parallelizing readout cycles.
- b. Replacement of DDL and RORC cards with new generation (DDL3 and RORC3).

Main sub-systems constituting the HMPID detector

MODULES	
7	CsI RICH chamber with radiator
7	System instrumenting 23 040 pad channels for analog multiplexed readout, digitization and zero suppression
AUXILIARY	
1	Evaporation plant for production of CsI photocathodes
1	Storage plant for CsI photocathodes
1	Test and monitoring system
1	High-Voltage supply system
1	Control signal and trigger electronics system
1	Low-Voltage supply system
1	Data transfer system
1	Data acquisition system
1	Main gas mixture supply with purification and contaminant control systems
1	Main C <sub>6</sub> F <sub>14</sub> supply and system for circulating the liquid through the 7 modules according to gravity flow scheme
1	Slow-control and monitoring system

Collaboration and Data Integration

Data Handling:

- a. Depending on achievable readout rate, data may be downscaled.
- b. Information combined with other central detectors at the event building stage.

Collaboration and Synergy:

Collaborative efforts within ALICE to optimize overall detector performance.

The signals to be measured for the HMPID are listed in the following table:



Main parameters of the detector control system for the HMPID

Systems Subsystems	Location	Controlled parameters	Number	Type	Parameters	Control
Gas supply	PX24	Primary flows	20	Analog	Flow	Read
	PX24	Primary pressures	10	Analog	Pressure	Read
	Detector	Temperatures	20	Analog	Temperature	Read
	PX24		5	Serial IF	Complex	Read
	PX24	Safety switch	1	Binary	Voltage	On, Off
	PX24	Purity control	2	Serial IF	Complex	Read
	UX25	Gas pressure MWPC	14	Analog	Pressure	Read
	Detector	Temperatures	80	Analog	Temperature	Read
Radiator	UX25	Gas flow MWPC	7	Analog	Flow	Read
	UX25	Circulator valves	80	Binary	Voltage	ReadWrite
	PX24	Pumps & circulators	32	Binary	Voltage	On, Off
	PX24	Liquid flow	64	Analog	Flow	Read
	PX24	Pressure	10	Analog	Pressure	Read
	Detector	Temperature	80	Analog	Temperature	Read
	PX24	VUV transp. Syst.	1	Serial IF	Complex	Read
	PX24	Safety system	1	Binary	Voltage	On, Off
Other system	PX24	VUV transp. Syst.	1	Serial IF	Complex	Read
HV	PX24	Chamber voltage	12	Analog	Voltage	ReadWrite
	PX24	Chamber current	14	Analog	Current	Read
	PX24	Current limits	14	Analog	Thresholds	ReadWrite
LV	PX24	Readout electronics	42	Analog	Voltage	ReadWrite
	PX24	RO sign. Cntrl	42	Binary	Voltage	On, Off
	PX24	FEE	42	Binary	Voltage	On, Off
	PX24	MWPC FEE supply	28	Analog	Voltage	ReadWrite
	PX24	FEE current monitoring	28	Analog	Current	Read
	PX24	Current limits	28	Analog	Thresholds	ReadWrite
	PX24	chamber	42	Analog	Voltage	ReadWrite
	PX24	chamber	42	Analog	Current	Read

The validation of design choices for the overall ALICE DCS will be performed for a liquid circulator system of the HMPID but an adaptation to other applications is envisaged.

For this purpose, a small test and evaluation station is being set. The system is entirely based on standard industrial components following the recommendations of the relevant working groups. The realisation of this first stand-alone system for the control of a detector sub-system will cover all layers of the proposed DCS architecture:

Supervisory Software: LabView/BridgeView

Control Software: Siemens Step7, equivalent to IEC1131

PLC programming libraries

Controller station: Siemens S7 + TCP/IP

Field instrumentation: Temperature sensors, Switches, Valves

## 8. Zero Degree Calorimeter (ZDC):

Purpose:

- Measures energy deposited by spectator nucleons to determine the overlap region in nucleus-nucleus collisions.
- Provides information in various collision systems: nucleus-nucleus, proton-nucleus, and proton-proton runs.

Components:

- c. Two sets of hadronic calorimeters for spectator neutrons (ZN) and protons (ZP).
- d. Forward EM calorimeters (ZEM) for discriminating collision centrality.

The signals to be measured for the ZDC detector are listed in the following table:

Main parameters of the detector control system for the ZDC detector.						
System	Location	Controlled parameter	Number	Type	Parameters	Control
HV	PX24	PMT voltage	50	Analog	Voltage	ReadWrite
	PX24	PMT current	50	Analog	Current	Read
	PX24	PMT current limits	50	Analog	Threshold	ReadWrite
	PX24	PMT ramp up/down	50	Analog	Voltage	ReadWrite
Detector	PX24	Safety switch	1	Binary	Voltage	On, Off
	PX24	Purity control	2	Serial IF	Complex	Read
	UX25	Gas pressure MWPC	14	Analog	Pressure	Read
	UX25	Temperatures	80	Analog	Temperature	Read
	UX25	Gas flow MWPC	7	Analog	Flow	Read
Radiator	UX25	Circulator valves	80	Binary	Voltage	ReadWrite
	PX24	Pumps & circulators	32	Binary	Voltage	On, Off
	PX24	Liquid flow	64	Analog	Flow	Read
	PX24	Pressure	10	Analog	Pressure	Read
	Detector	Temperature	80	Analog	Temperature	Read
	PX24	VUV transp. Syst.	1	Serial IF	Complex	Read
	PX24	Safety system	1	Binary	Voltage	On, Off
Other system	PX24	VUV transp. Syst.	1	Serial IF	Complex	Read
HV	PX24	Chamber voltage	12	Analog	Voltage	ReadWrite
	PX24	Chamber current	14	Analog	Current	Read
	PX24	Current limits	14	Analog	Thresholds	ReadWrite
LV	PX24	Readout electronics	42	Analog	Voltage	ReadWrite
	PX24	RO sign. Cntrl	42	Binary	Voltage	On, Off
	PX24	FEE	42	Binary	Voltage	On, Off
	PX24	MWPC FEE supply	28	Analog	Voltage	ReadWrite
	PX24	FEE current monitoring	28	Analog	Current	Read
	PX24	Current limits	28	Analog	Thresholds	ReadWrite
	PX24	chamber	42	Analog	Voltage	ReadWrite
	PX24	chamber	42	Analog	Current	Read

## 9. Fast Interaction Trigger (FIT):

Role:

Ensures effective triggering for measuring hard processes with reduced signal background.

## 10. Charged Particle Veto Detector:

Purpose:

- a. Designed to prevent detection of charged particles on the PHOS front surface.
- b. PHOS comprises 17,920 lead tungstate crystal-based analogue detection channels.

Structure:

CPV has three separate modules, each covering an area of 200 x 230 cm<sup>2</sup>, positioned atop PHOS modules.

Integrated Preamplifier:

Preamplifier integrated with PIN photodiode, optimized for low energies (up to 10 GeV).

Readout Plans:

- a. PHOS aims to upgrade readout firmware to 30 - 40 kHz.
- b. CPV readout speed targets to match or exceed PHOS capabilities.

**The ALICE High Level Trigger at the LHC:**

The HLT is a compute farm composed of 180 worker nodes and 8 infrastructure nodes. It receives an exact copy of all the data from the detector links.

After processing the data, the HLT sends its reconstruction output to the Data Acquisition (DAQ) via dedicated optical output links.

	Run 1 farm	Run 2 farm
CPU cores	Opteron / Xeon 2784 cores, up to 2.27 GHz	Xeon E5-2697 4480 cores, 2.7 GHz
GPUs	64 × GeForce GTX480	180 × FirePro S9000
Total memory	6.1 TB	23.1 TB
Total nodes	248	188
Infrastructure nodes	22	8
Worker nodes	226	180
Compute nodes (CN)	95	172
Input nodes	117	(subset of CNs) 66
Output nodes	14	8
Bandwidth to DAQ	5 GB/s	12 GB/s
Max. input bandwidth	25 GB/s	48 GB/s
Detector links	452	473
Output links	28	28
RORC type	H-RORC	C-RORC
Host interface	PCI-X	PCI-Express
Max. PCI bandwidth	940 MB/s	3.6 GB/s
Optical links	2	12
Max. link bandwidth	2.125 Gbps	5.3125 Gbps
Clock frequency	133.3 MHz	312.5 MHz
On-board memory	128 MB	up to 16 GB

Overview of the HLT Run 1 and Run 2 production clusters.

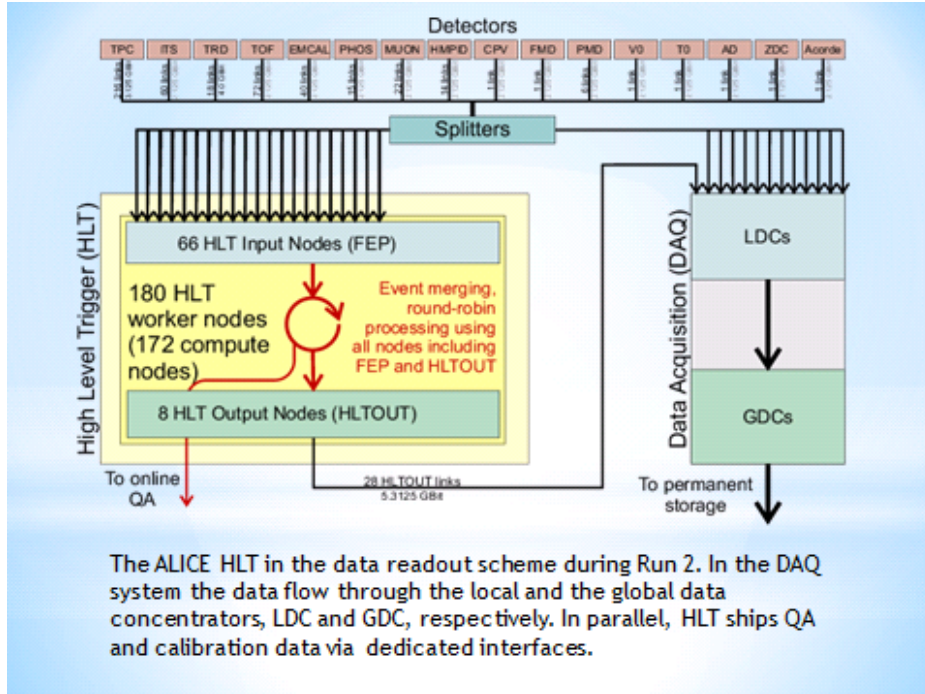

The compute nodes use off-the-shelf components except for the Read Out Receiver Card (RORC), which is a custom FPGA-based card developed for Run 1 and Run 2. During LHC Run 1 the HLT farm consisted of 248 servers including 117 dedicated Front-End Processor (FEP) nodes equipped with RORCs for receiving data from the detectors and sending data to DAQ.

The servers consisted of standard compute nodes, each equipped with either AMD Magny-Cours twelve-core CPUs or Intel Nehalem Quad-core CPUs. Among them, 64 nodes had NVIDIA Fermi GPUs for hardware acceleration in track reconstruction. Additionally, there were about 20 infrastructure nodes for tasks like provisioning, storage, database services, and monitoring.

The cluster had two separate networks: a gigabit Ethernet network for management and a fast fat-tree InfiniBand QDR 40 Gbit network for data processing. Remote management of compute nodes utilized a custom FPGA-based CHARM card and BMC (Board Management Controller) iKVM, which supports IPMI (Intelligent Platform Management Interface) standard in new compute nodes.

### ALICE Control Coordination (ACC):

the functional unit mandated to co-ordinate the execution of the Detector Control System (DCS) project.

- Technical competencies in ACC:
  - Safety aspects (member of ACC is deputy GLIMOS)

- System architecture
- Control system development (SCADA, devices)
- IT administration (Windows, Linux platforms, network, security)
- Database development (administration done by the IT department)
- Hardware interfaces (OPCS, CAN interfaces)
- PLCs

### The DCS context and scale:

### The ALF-FRED role in the DCS data stream:

ALICE is based on the WinCC Open Architecture (WinCC-OA) software system and on the JCOP (Joint Controls Project) Framework software package that provides tools (FSMs, database access, access control, basic user interfaces, configuration, etc.) for DCS development.

The JCOP Framework was developed at CERN by members of the four major LHC experiments (ATLAS, CMS, ALICE and LHCb) and a CERN support group to reduce the effort and cost to develop the DCS. Experimental equipment such as power supplies and readout devices can easily be integrated in WinCC-OA by using JCOP Framework. The installation of new FEE for Run 3 required the development of the whole Front-End DCS subsystem. The Front-End

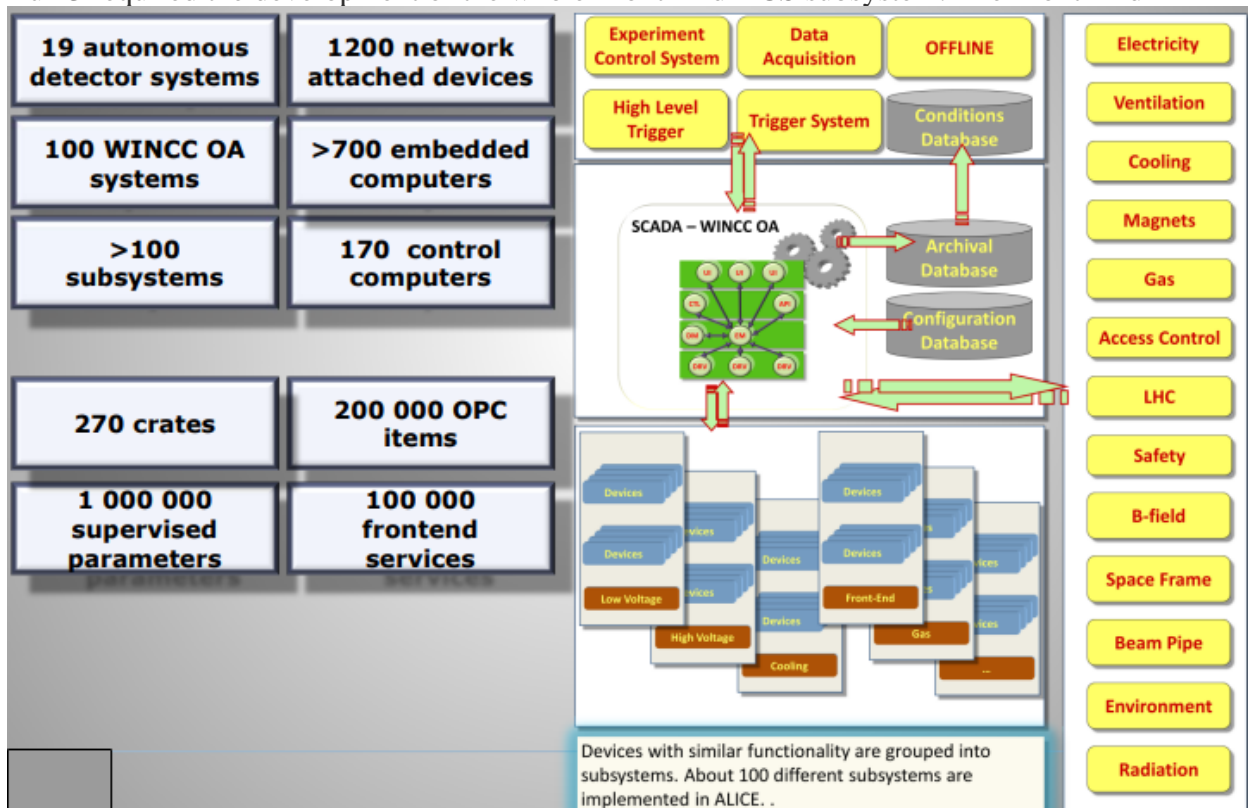

modules in the ALICE experiment use the CERN developed GigaBit Transceiver (GBT) link to

transfer detector signals to the DCS and the O2 systems. GBT links are controlled by the Common Readout Units (CRU) installed in the FLPs. Here, the physics and DCS data (control, monitoring, and conditions data) are passed to the ALICE Low Level Front-End (ALF) interface. Communication between the WinCC-OA systems and the ALFs is managed by the Front-End Device (FRED) module (see Fig. 7), which provides the translation of high-level WinCC-OA commands to ALF low-level commands and unpacks the ALF data before they are published to the WinCC-OA

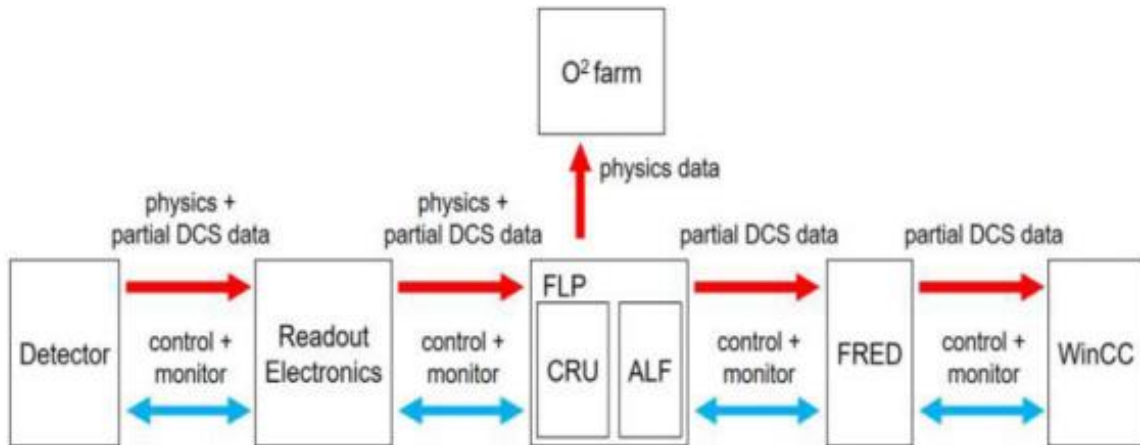

The ALF-FRED role in the DCS data stream

**Points do not be covered:**

The (SPD), LHCIF and sub-detectors i could not find any information about them

**Results:**

Feature	Alice	BM@N
<b>Facility characteristics Development</b>		
number of subsystems	150	can calculate later
FED ( second step which linked with FEE)	–	–
number of detectors	19	10



number of participants in the collaboration	2000 scientists from 174 physics institutes in 40 countries	8 participants JINR (9 FTE), FAIR (8.5 FTE), U Tübingen (1 FTE), WUT Warsaw (2 FTE), Wigner Budapest (2 FTE), MEPHI (4 FTE) INR Moscow (1 FTE), NPI Prague (2 FTE)
years of operation	10 years	6 years
<b>Hardware</b>		
number of front end electronic	42	84
number of signals	about 5	–
number of PLC	The safety system is based on a Siemens S7-1500 PLC device.	Cooling System Control using the PLC Siemens S7-1200 simulator
type of FEE	two types of VME boards: Trigger and Clock Module (TCM) and Processing Module (PM).	The STS FEE electronics TIGER ASIC (INFN, Italy) two new ASICs (VMM3a and TIGER)
number of crates	270	8
network attached device	> 700 embedded computer 1200 network attached device	54 Number of Embedded Computers or Network Devices
number of servers	up to 750 servers	100 server
<b>Software</b>		
type of Operation Systems	Linux kernels,HP-Unix 10.20, Linux Red Hat 6.0	linux debian based - for tango control system, web applications can be run in any OS
SCADA	Top-level application based on PVSS software.	only TangoControl (Sole SCADA system employed)



	<b>SIMATIC WinCC Open Architecture</b>	
database	<ul style="list-style-type: none"> <li>● The WCC device configuration database power supply setting, various configuration parameters all managed by the JCOP framework tools</li> <li>● The frontend configuration database free format, detector-specific data Managed by detector tools</li> <li>● The DCS ARCHIVE The main DCS storage Contains all measured data Main source of DCS data for OFFLINE analysis</li> </ul>	3 database servers, acts as a backup for other servers also , one archive data, 2 for reading data graphane fro example
Protocols	<ol style="list-style-type: none"> <li>1. Communication Framework: <ul style="list-style-type: none"> <li>● DIM (Distributed Information Management)</li> </ul> </li> <li>2. Device Control and Monitoring: <ul style="list-style-type: none"> <li>● OPC (OLE for Process Control)</li> </ul> </li> <li>3. Supervisory Control and Data Acquisition (SCADA): <ul style="list-style-type: none"> <li>● PVSS (Process Visualization and Supervisory System)</li> </ul> </li> <li>4. Event Building and Data Acquisition:</li> <li>5. ALICE Data Acquisition (DAQ) System Protocols</li> </ol> <p>Standard Networking Protocols:</p> <ul style="list-style-type: none"> <li>● Ethernet</li> </ul> <ol style="list-style-type: none"> <li>6. CANbus (Controller Area Network): <ul style="list-style-type: none"> <li>● CANbus Protocol:</li> </ul> </li> </ol>	<ol style="list-style-type: none"> <li>1. DIM (Distributed Information Management): DIM is often used for communication and data exchange in distributed systems. It provides a publish/subscribe mechanism for inter-process communication.</li> <li>2. OPC (OLE for Process Control)</li> </ol>
Development studio for FEE, FED	<ol style="list-style-type: none"> <li>1- Hardware Description Languages (HDLs): VHDL (VHSIC Hardware Description Language) or Verilog</li> <li>2- Simulation Tools: ModelSim</li> <li>3- FPGA Development Tools: Xilinx Vivado or Altera Quartus</li> <li>4- Embedded Software Development: C/C++</li> <li>5- Linux or Real-Time Operating Systems</li> </ol>	<ol style="list-style-type: none"> <li>1-Hardware Description Languages (HDLs): VHDL (VHSIC Hardware Description Language) or Verilog</li> <li>2- ModelSim: ModelSim</li> <li>3- FPGA Development Tools: Xilinx Vivado or Intel Quartus: If Field-Programmable Gate Arrays (FPGAs)</li> <li>4- Embedded Software Development:</li> </ol>

	<p>(RTOS)  Version Control Systems:      Git, SVN: Version control systems  6- Testing and Debugging Tools:      JTAG (Joint Test Action Group)  7- Documentation Tools:      LaTeX, Doxygen</p>	<p>C/C++ Programming  Linux or Real-Time Operating Systems (RTOS):  5- Version Control Systems  Git, SVN  6- Testing and Debugging Tools:  JTAG (Joint Test Action Group)  7- Documentation Tools:  LaTeX, Doxygen</p>
<p>frameworks</p>	<p>Supervisory Control (SCADA), Distributed Control System (DCS), and Hardware Control. It employs standardized hardware across detector boundaries, including field instrumentation, control computers, and workstations. Communication relies on Ethernet with a CAN interface backup. The software uses Linux-based controllers, follows a layered communication architecture, and implements the OPC standard for driver software. Safety measures include monitoring, alarms, and interlock logic. The development involves three phases, utilizing single-board CPUs and programmable gate arrays.</p>	<p>Supervisory Control and Data Acquisition (SCADA):</p> <ul style="list-style-type: none"> <li>● Central system for monitoring and controlling the detector. <ul style="list-style-type: none"> <li>Distributed Control System (DCS):</li> </ul> </li> <li>● Manages subsystems, hardware control, and data acquisition. <ul style="list-style-type: none"> <li>Hardware Control:</li> </ul> </li> <li>● Controls Front-End Electronics (FEE) and Front-End Drivers (FED). <ul style="list-style-type: none"> <li>Communication Protocols:</li> </ul> </li> <li>● Uses DIM and OPC for communication. <ul style="list-style-type: none"> <li>Firmware and Software:</li> </ul> </li> <li>● Develops firmware and software in languages like C/C++.</li> <li>Simulation Tools: <ul style="list-style-type: none"> <li>● Uses simulation tools for testing.</li> </ul> </li> <li>Testing and Debugging: <ul style="list-style-type: none"> <li>● Implements testing and debugging tools.</li> </ul> </li> <li>Documentation: <ul style="list-style-type: none"> <li>● Documents software, firmware, and system architecture.</li> </ul> </li> <li>Security Measures: <ul style="list-style-type: none"> <li>● Implements security protocols.</li> </ul> </li> </ul>

<b>Logical Algorithm</b>		
number of operation modes	three operation mode(JTAG,MCM,ALICE)	static for all power supply
number of interlocks	–	–
number of control loops		
number of Alarms	UI in ALICE presents all level 3 alarms	–
number of step program	–	–
<b>Use human machine interface</b>		
MIMIC panels	–	–
Alarm function	1- Alarm Monitoring: ALICE DCS 2- Real-time Notifications: 3- MIMIC Panel Display 4- Configurability: 5- Severity Classification 6- Integration with Logging documentation. 7- Detector Health Maintenance 8- Operator Response: 9- Multi-level Alarming 10- Facilitates Rapid Resolution:	the same of ALICE DCS
face plates	<ul style="list-style-type: none"> <li>● It serves as graphical user interfaces.</li> <li>● They provide real-time monitoring of system data and status.</li> <li>● Operators use faceplates to control and adjust system parameters.</li> <li>● Faceplates offer a graphical representation of the detector layout.</li> <li>● They contribute to efficient and intuitive system operation.</li> <li>● Integrated into the ALICE DCS framework for seamless</li> </ul>	<ul style="list-style-type: none"> <li>● It acts as user interfaces for system control and monitoring.</li> <li>● They offer a graphical representation of the detector components and parameters.</li> <li>● Real-time data and status updates are displayed on faceplates for quick assessment.</li> <li>● Operators use faceplates to</li> </ul>

	<p>communication.</p> <ul style="list-style-type: none"> <li>● Specific features may vary based on system configuration and version.</li> </ul>	<p>interact with the DCS, adjusting settings and parameters.</p> <ul style="list-style-type: none"> <li>● Integrated into the broader BM@N DCS framework for cohesive system management.</li> <li>● The design and features of faceplates may vary based on the specific BM@N DCS configuration.</li> <li>● Enhance overall user experience and facilitate efficient operation of the detector system.</li> </ul>
hierarchy panels	yes	yes
trends	<p>1- Advanced Technologies:</p> <ul style="list-style-type: none"> <li>● Integration of modern technologies.</li> <li>● Embracing IoT and edge computing.</li> </ul> <p>2- Enhanced User Interfaces:</p> <ul style="list-style-type: none"> <li>● Improved user interfaces.</li> <li>● Modern visualization techniques.</li> </ul> <p>3- Increased Automation:</p> <ul style="list-style-type: none"> <li>● Streamlining operations through automation.</li> <li>● Automation of routine tasks.</li> </ul> <p>4- Data Analytics and ML:</p> <ul style="list-style-type: none"> <li>● Use of data analytics tools.</li> <li>● Exploration of machine learning.</li> </ul> <p>5- Cybersecurity Measures:</p> <ul style="list-style-type: none"> <li>● Robust cybersecurity implementation.</li> <li>● Regular updates against threats.</li> </ul> <p>6- Remote Monitoring:</p> <ul style="list-style-type: none"> <li>● Enhanced remote monitoring capabilities.</li> <li>● Facilitating remote operations.</li> </ul> <p>7- Adaptation to Research Needs:</p> <ul style="list-style-type: none"> <li>● Flexible design for changing requirements.</li> <li>● Swift adaptation to new goals.</li> </ul>	same of ALICS DCS

	<p>8- Improved Alarm Systems:</p> <ul style="list-style-type: none"> <li>● Faster and accurate alarm systems.</li> <li>● Integration with mobile devices.</li> </ul> <p>9- Collaboration with Standards:</p> <ul style="list-style-type: none"> <li>● Collaboration with industry standards.</li> <li>● Regular updates in line with best practices.</li> </ul> <p>10- Energy Efficiency:</p> <ul style="list-style-type: none"> <li>● Optimizing energy consumption.</li> <li>● Energy-efficient solutions.</li> </ul> <p>11- Environmental Monitoring:</p> <ul style="list-style-type: none"> <li>● Improved environmental monitoring.</li> <li>● Tracking temperature, humidity, etc.</li> </ul> <p>12- Scalability and Modularity:</p> <ul style="list-style-type: none"> <li>● Design for scalability and modularity.</li> <li>● Easy integration of new components.</li> </ul> <p>13- Sustainability Initiatives:</p> <ul style="list-style-type: none"> <li>● Integration of sustainable practices.</li> <li>● Considering environmental impact.</li> </ul>	
<p>protection from wrong action</p>	<p>1- User Authentication:</p> <ul style="list-style-type: none"> <li>● Secure login with user authentication.</li> <li>● Role-based access control.</li> </ul> <p>2- Authorization Levels:</p> <ul style="list-style-type: none"> <li>● Different authorization levels for users.</li> <li>● Access restricted based on roles.</li> </ul> <p>3- Transaction Logging:</p> <ul style="list-style-type: none"> <li>● Comprehensive logging of user transactions.</li> <li>● Recording changes made by each user.</li> </ul> <p>4- Permission Management:</p> <ul style="list-style-type: none"> <li>● Granular permission settings.</li> <li>● Users only granted necessary access.</li> </ul> <p>5- Training and Awareness:</p> <ul style="list-style-type: none"> <li>● Training programs for users.</li> <li>● Awareness campaigns for</li> </ul>	<p>1- Interlocks: Detect abnormal conditions and trigger protective actions.</p> <p>2- Alarm Systems: Provide immediate notifications for deviations from normal parameters.</p> <p>3- Redundancy: Minimize impact of failures through redundant systems and components.</p> <p>4- Authorization Levels: Restrict access to critical functionalities based on user authorization.</p> <p>5- Monitoring and Logging: Continuously monitor system parameters and log events for analysis.</p>

	<p>responsible actions.</p> <p>6- Confirmation Prompts:</p> <ul style="list-style-type: none"><li>● Confirmation prompts for critical actions.</li><li>● Reducing accidental errors.</li></ul> <p>7- Error Prevention Measures:</p> <ul style="list-style-type: none"><li>● Implementing measures to prevent errors.</li><li>● Verifying input before executing actions.</li></ul> <p>8- Emergency Stop Procedures:</p> <ul style="list-style-type: none"><li>● Clearly defined emergency stop procedures.</li><li>● Immediate action in case of errors.</li></ul> <p>9- Regular Audits:</p> <ul style="list-style-type: none"><li>● Regular audits of user activities.</li><li>● Identifying and addressing anomalies.</li></ul> <p>10-Feedback Mechanism:</p> <ul style="list-style-type: none"><li>● Feedback loop for user suggestions.</li><li>● Constantly improving user experience.</li></ul> <p>11-Continuous Training:</p> <ul style="list-style-type: none"><li>● Ongoing training sessions.</li><li>● Keeping users updated on system changes.</li></ul> <p>12-Warning Systems:</p> <ul style="list-style-type: none"><li>● Implementing warning systems.</li><li>● Alerts for potential erroneous actions.</li></ul> <p>13-Secure Communication:</p> <ul style="list-style-type: none"><li>● Encrypted communication channels.</li><li>● Preventing unauthorized access.</li></ul> <p>14-Error Recovery Protocols:</p> <ul style="list-style-type: none"><li>● Protocols for recovering from errors.</li><li>● Minimizing the impact of mistakes.</li></ul> <p>15-User Accountability:</p> <ul style="list-style-type: none"><li>● Clear accountability for users.</li><li>● Encouraging responsible actions.</li></ul>	
--	--	--

organization		
control room	1	(7) one main control room, one control suit and 6 other control rooms.
workstation	20	40

### **Future work:**

For ALICE DCS involves ongoing efforts to integrate new detectors, enhance control algorithms, explore machine learning applications, improve the user interface, strengthen cybersecurity measures, implement remote monitoring and control features, develop a smart alarming system, research adaptive automation, and initiate energy efficiency measures. For BM@N DCS, the focus is on ensuring system scalability, enhancing data handling capabilities, improving real-time monitoring, streamlining communication between interconnected subsystems, adopting industry standards, ensuring cross-platform compatibility, upgrading control algorithms, establishing a long-term maintenance plan, engaging in collaborative research initiatives, and providing continuous user training programs to empower users with evolving system capabilities.

### **Acknowledgement:**

I extend my heartfelt gratitude to JINR and Mr. Nikita for their continuous support and encouragement. Your guidance and assistance have been instrumental in my endeavors, and I am sincerely thankful for the invaluable contributions that have significantly enriched my professional journey.